



Smart Cane for Visually Impaired with Obstacle, Water Detection and GPS

Nur Maisarah Ahmad Nazri¹, Shukor Sanim Mohd Fauzi^{1,*}, Ray Adderley JM Gining¹, Tajul Rosli Razak¹ and Muhammad Nabil Fikri Jamaluddin¹

¹Faculty of Computer and Mathematical Sciences, Universiti Teknologi MARA, Perlis Branch, 02600 Arau, Perlis, Malaysia

Received 1 Apr. 2020, Revised 6 Jul. 2021, Accepted 7 Aug. 2021, Published 28 Dec. 2021

Abstract: Visual impairment is a condition that distresses the structure and functions of the visual system. Many people believed blindness to be anything from seeing light to none at all. In the context of visual impairment, many people have trouble finding their way autonomously in an unfamiliar environment. In most cases, individuals who are visually impaired use the traditional white cane and/or walking cane to walk. Nevertheless, their safety can be compromised while traveling in unknown, unsafe locations. Smart cane has become one of the alternatives to assist visual impaired to eliminate the issues. However, there are some shortcomings in the current development of the smart cane. Therefore, in this paper, we proposed a smart cane by combining it with ultrasonic sensors to detect obstacles, water sensors for detecting puddles, and GPS to track the blind's location. A total of ten respondents with age above twenty years old involved in the functionality test to identify the effectiveness of the proposed system. From the results, the proposed smart cane is shown to be capable of increasing the safety of visually impaired person in unfamiliar, outdoor areas.

Keywords: Visually impaired, Smart cane, Internet of Things, IoT, GPS.

1. INTRODUCTION

People with visual impairments are the people who find it hard to recognize the smallest element with healthy eyes. In 2010, 32.4 million people were blind, and 191 million people had mild or greater vision loss [1].

The issues with visual impairment lie in the difficulty in navigating in unfamiliar environments. The use of the conventional cane, guide dogs, and mobility training would be included within the spectrum of knowledge required to work in the area of orientation and mobility to support visionless people [2]. Users usually tap their canes from left to right and far ahead. The tapping technique help users to recognize about ground surface in the user's environment [3]. However, the problem with the standard white cane is that it has a limited detection range of obstacles at only a distance equals to the cane's length. Thus, this restricts the users' walking speed and leads the users to assess approaching obstacles outside of the range unconfidently.

Additionally, outdoors could also be a dangerous place for individuals with visual impairment. This is because visually impaired people tend to expose to water puddle or wet walkway. Water puddle may cause visually impaired people to slip and fall. Further, when they slipped and fell, it is possible for them to get head or below knee-level injuries.

It could be worse if there are other objects such as a rock in the water puddle that obstructs their way.

This study provides another piece of work and future research direction by providing an alternative solution in the smart cane body of knowledge and development. The proposed smart cane integrates three different devices which are obstacle detection, water detection and also GPS module to monitor the visually impaired location. This paper is structured as follows; the literature review is listed in Section 2. System design and development is explained in Section 3. Results presented in Section four, and the paper is concluded in Section five.

2. LITERATURE REVIEW

A. Visually Impaired

Visual impairment can be defined as an impairment of the visual system that affects the level of function. The individuals with vision impairment may also experience disability if they do not have adequate access to support and services, and face barriers such as discrimination or isolated buildings or transport [4]. On top of that, many people believe that people who are blind are unable to see or sense light at all. The World Health Organization estimates that there are 285 million blind and 246 million with low vision; 39 million of the blind are visually impaired and 246 million have low vision. There are some different levels of



visual impairment that affect a person's daily life in different ways. For instance, people with a severe visual impairment may not be able to legally drive and also they may not be able to distinguish the difference between light and dark.

Typically, people with visual impairment are always exposed to an external environment. On the other hand, some places are quite dangerous and challenging for those who are visually impaired as those places will increase the chance of an accident. More than 700,000 people in the United Kingdom (UK) attend the hospital's accident and emergency department each year regarded falls and many more minor injury units [5]. In particular, the number of fall-related accident in the UK in 1999, requiring medical attention is 2.35 million in total, and 8.04% of them are individuals with visual impairment [5]. Based on the statistics, it is suggested that visual impairment people need some aid to interact with their environment with higher safety because this situation burdened visually impaired people with problems and challenges in navigating themselves in outdoor environments.

In the context of visually impaired, the common types of mobility aids were canes and guide dogs [6]. A guide dog is a mobility aid that allows the blind to safely move. Guide dogs can guide people around obstacles, through crowds and stop at curbs or stairs. Guide dogs assisted visually impaired in navigating them to walk. However, navigating was alone is not enough to give a high guarantee to protect visually impaired from the obstacles that they faced. Approximately, the guide dogs cost \$10,000 for training and to maintain them would cost about \$20 per month [6]. The guide dog is not suitable for all visually impaired, due to its certain limitations. The reason why it was not suitable to use guide dog as mobility aid was because of poor social behaviour such as scavenging [7].

On top of that, dogs were not allowed to enter public places such as hotels, public transport and many more [8]. In addition, guide dogs need extensive training so that the pace the dog runs would be consistent with the user. Typical walking speed is 5 to 6 kilometres per hour [7]. In conjunction, it is clear that guide dogs were not appropriate to be used as mobility aid because they did not assist the visually impaired enough in order to avoid them from obstacles.

The cane or stick has existed as travelling supports for the blinds and visually impaired yet it was not just a device that can be used to seize self-reliance, but it was also a sign of the sightless people in society [9]. They used such tools to alert them the obstacles in their way. There are several types of cane which include a long cane, symbol cane, and guide cane. Long cane merely was familiar as the traditional 'white cane' designed for people who have no functional vision and required a contact cane for wayfinding and obstacle location [10]. Moreover, long cane also checked the path 1.5 to 2 steps ahead of the visually impaired, so

they had the warning about any obstacles, hazards or surface changes [10]. Symbol cane is another version of a long cane with the difference if it is shorter than a long cane. Symbol cane is not used for checking the area in front of the visually impaired person but for letting people around them knew that they are blind or have partially sighted [10]. Guide cane is another type of cane for blind people. It is useful for people with a lower level of visual function to avoid obstacles, similar to long canes but different in the way it is carried and is for locating obstacles such as kerbs and stairs [10].

Nonetheless, it was not enough for visually impaired because traditional cane does not provide information about obstacles or water puddles thus cannot give the high guarantee to protect themselves and being away from all level of obstacles [11]. To address this, a few smart canes was proposed. However, a little study proposed a smart cane by integrating obstacle detection, water detection and GPS module to monitor the location of visually impaired.

This study contributes the following 1) proposed smart cane can be developed with a minimal cost but with several features such as a capability to detect the presence of obstacles ahead of the visually impaired by using the ultrasonic sensor, and also is also integrated with a water level sensor in for water puddles detection. Moreover, this smart cane is capable to update the location of the visually impaired over IoT platform using GPS Module and Blynk App.

3. SYSTEM DESIGN AND DEVELOPMENT

This section outlines the overall design effort for AAMS. The section is divided into three sub-sections; (i) the flow of the proposed system; (ii) the hardware used in the proposed system; and (iii) the software configuration.

A. Flow of the Proposed System

Figures 1 and 2 illustrate the process of the proposed smart cane. The process started when the stick used by visually impaired was initiated. Once the visually impaired reaches at least 50 cm distances from the obstacles, the buzzer will produce a "beep" sound to alert the user that there are obstacles in front of them. In the case of the visually impaired approaching water puddle on the road and the water, sensor touch the water, the buzzer will also be triggered.

The GPS track the location of the visually impaired via Blynk application. In the Blynk application, information on location such as latitude and longitude and also the map are displayed in the application.

Next section discussed the hardware requirement for this study.

B. Hardware Setup

The Node MCU, in other words the ESP8266 module, is an especially proficient wireless programmable microcontroller board. The ESP8266 Wi-Fi board is a special form

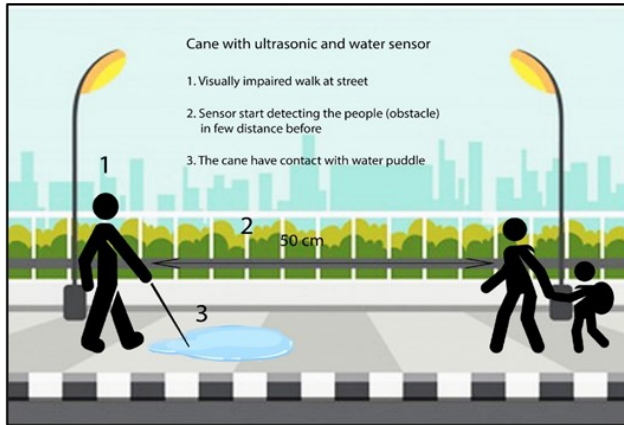

Figure 1. A short overview of the smart cane

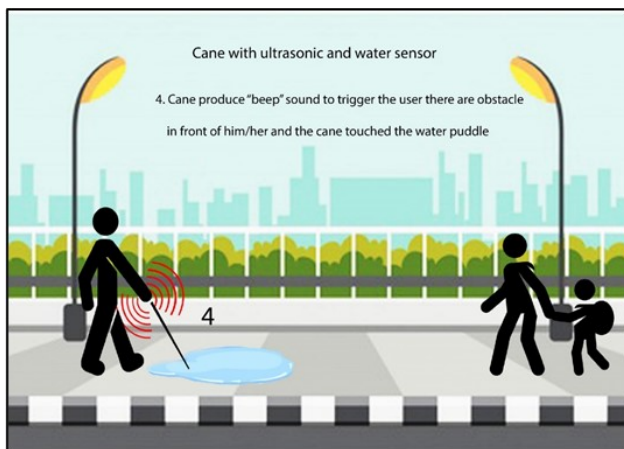

Figure 2. A short overview of the smart cane

of secondary microcontroller which can give the primary microcontroller access to the Wi-Fi network. The ESP8266 board can either be used as an application processor or be used as a WiFi adapter. Thus, this is more suited to be used as a node that is capable of sensing data from different interconnected IoT nodes and transmitting the data to the central server [12]. ESP8266 is perfect for wireless devices as it has various peripheral functions. The process and transfer information to the web server can be used from Node-MCU so that the smartphone can access the information.

The ultrasonic sensor emits a sequence of brief, high-pitch sonic pulses and waits for the high-pitched signal to be heard. Since the speed of sound is constant with the value of 340.29 m/s, the time from the signal to the source is measurable and the distance can be measured. The sensor consists of a trig pin, echo pin, out pin, integrated power supply pin or 'vcc' and 'gnd' the ground pin. However, in this project, pins used were trig pin, echo pin, 'vcc' and 'gnd'. The sensor begins the sonar by generating an echo that travels across the sonar. Once it hit the object, it will

return to the sensor, and trig pin will read for further action. The HY-SRF05 used 5V of power on the breadboard. The sensor was able to read distances up to 450 cm. For this project, the distance setup was in the range of 0 to 50 cm for triggering the buzzer.

Water sensor work to detect the presence of the water, in which consisted of three pins which were S, positive pin, and negative pin. S is the pin where the output goes to an analogue signal on Node-MCU. On the other hand, the positive pin or 'vcc' works as power supply and the negative pin are the 'gnd' or ground pin. Water sensor only required 3.3V without any support components in between them. Generally, the water sensor functions to read the level of water. For this project, the water level does not matter. The water sensor generally is capable of reading the water level. However, in this project, the focus is on the presence of water which means when the sensor able to touch the water, the buzzer will be triggered.

A passive buzzer relies on an applied AC signal to create sound. It's like an electrostatic speaker where a changing electrical input signal generates the sound, rather than generating a tone automatically. In this study, the buzzer was used to trigger the user by producing 'beep' sound. The buzzer consisted of two pins which are positive and negative. The buzzer used the 'D1' pin on Node-MCU for the positive pin and 'D2' for the negative pin with two of the jumper wire.

The Global Positioning System (GPS) utilizes 24 satellites to establish an accurate and easily accessible form of navigation. GPS technology works under any climate conditions, anywhere in the world, at any time with no setup charges. The NEO-6 series of modules, which integrates the u-blox 6 positioning engine and was used in this analysis. These ultra-compact receivers provide different networking options in a miniature 16 x 12.2 x 2.4 x 6 mm package. GPS has four pins in total, which are 'vcc', 'rx', 'tx' and 'gnd'. In this project, 'vcc' pin connected to 3V3 pin, 'rx' works to receive data in which it is connected 'D1' and 'tx' connected to 'D2' works to transmit data while 'gnd' is ground.

Fritzing software then was used to visualise the schematic diagram of the study. Figure 3 illustrates the schematic diagram of the proposed study.

The sensor consists of the trig, echo, out, integrated power supply or 'vcc' and 'gnd' the ground pin. However, in this project pins used were trig pin, echo pin, 'vcc' and 'gnd'. The sensor works in a manner that spreads the sonar around the field. If it has entered the sensor, the trig pin will activate a relay to allow the object to be relocated. The HY-SRF05 used 5V of power on the breadboard. The sensor was able to read distances up to 450 cm. For this project, the distance used was in the range of 0 to 50 cm for triggering the buzzer.

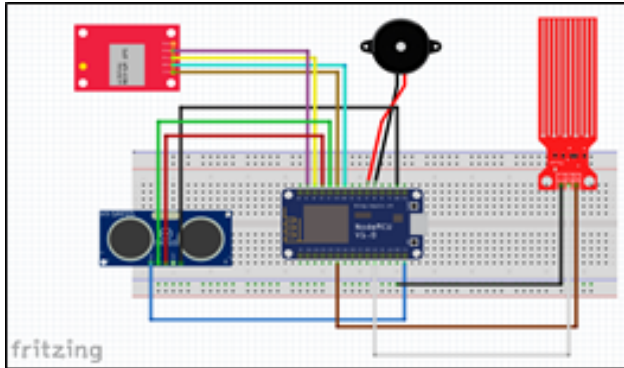

Figure 3. Schematic diagram of the proposed study

Water level sensor consisted of three pins which were S, positive pin, and negative pin. S is the pin where the output goes to an analog signal on Node-MCU. On the other hand, the positive pin or 'vcc' functions as power supply and the negative pin are the 'gnd' or ground pin. Water level sensor only required 3.3 V without any support components in between them. The water level sensor generally is capable of reading the water level. However, as this project focused on the presence of water, as the sensor able to touch the water, the buzzer will be triggered. The buzzer used the 'D1' pin on Node-MCU for the positive pin and 'D2' for the negative pin with two of the jumper wire.

C. Software Configuration

In order to program the Node-MCU, the Node-pin MCU's that connected to it needed to be specified first, as in Figure 4. As for the ultrasonic sensor and water sensor, both did not require program library. The first step is to define the pins for all components connected with Node-MCU, which are ultrasonic sensor, water sensor and buzzer. For example, the ultrasonic sensor trig pin is connected to the 'D4' pin on Node-MCU - as the similar goes for the other components. The void setup function starts to initiate variables and pin modes, either input or output. The setup function will only run once for each power-up of the Node-MCU. The serial begin command sets the data rate in bits per second. The higher the rate a data file is processed, the faster the operation of Node-MCU. For this project, it was set to data rate 115200 bauds which to make the processing for the board rapid.

In this case, source code for GPS cannot be integrated with ultrasonic and water level sensor sketch. This was due to the ultrasonic sensor, water level sensor and GPS module cannot have two parallel processes. The solution have been taken to solve this problem was by using two Node-MCU of which one was for ultrasonic sensor, and water level sensor and the other one for the GPS module. Figure 5 depicts the libraries for the GPS module that need to be used in order to make it work.

Then we studied the pins that were used to create the circuit board. RXPin was connected to the D1 pin on the

```
// Define pins for ultrasonic, buzzer and water sensor
int const trigPin = D4;
int const echoPin = D3;
int const piezoPin = D1;
int analogInPin = A0;

void setup()
{
  pinMode(trigPin, OUTPUT); // trig pin will have pulses output
  pinMode(echoPin, INPUT); // echo pin should be input to get pulse width
  pinMode(D1, OUTPUT); // buzz pin is output to control buzzering
  pinMode(D2, OUTPUT); // buzz pin is output to control buzzering
}
```

Figure 4. Code Snippet

```
#include <TinyGPS++.h>
#include <SoftwareSerial.h>
#define BLYNK_PRINT Serial
#include <ESP8266WiFi.h>
#include <BlynkSimpleEsp8266.h>
```

Figure 5. Code Snippet for GPS libraries

NodeMCU while TXPin was connected to 'D2' pin. The rest code snippet in Figure 6 was for connection to Wi-Fi hotspot, GPS and Blynk App. Connection for all these was necessary in order to make the GPS worked without a glitch.

The primary process for this program is the loop section. In this segment, the loop function allows the developer to change and respond to the pin. It regulates the actions of Node-MCU by providing the task for which it must accomplish. The sequence of the loop started with declaring all variables in order to calculate duration, distance and water level.

The loop would process the sensor by giving it a condition to carry out a certain task. In this project, the ultrasonic sensor would activate the buzzer if the distance is in the range of 0 to 50 cm. The same goes to the water sensor, and it would activate the buzzer as well if the value read by the sensor is greater than 0, which means the sensor came into contact with water.

Since this project was using two different sensors, there

```
static const int RXPin = 4, TXPin = 5; // GPIO 4=RX(connect Tx of GPS) and GPIO 5=TX(connect Rx of GPS)
static const int RXD_5_GSMHead = 9400; //If baud rate 9600 didn't work in your case then use 4500

TinyGPSPlus gpr; // The TinyGPS++ object
HardwareSerial mySerial(VCC); // VCC for virtual pin of Map Widget

SoftwareSerial serial(RXPin, TXPin); // The serial connection to the GPS device

Signalifier sizer;

float speed; //Variable to store the speed
float meter; //Variable to store no. of satellite response
String bearing; //Variable to store orientation or direction of GPS

char work[] = "123456789012345678901234567890"; //Your Project authentication key
char ssid[] = "MyWiFi"; // Name of your network (Hotspot or Router name)
char pass[] = "1234567890"; // Corresponding Password

unsigned int move_index; // moving index, to be used later
// unsigned int move_index = 1; // Fixed location for now
```

Figure 6. Code Snippet for GPS setup

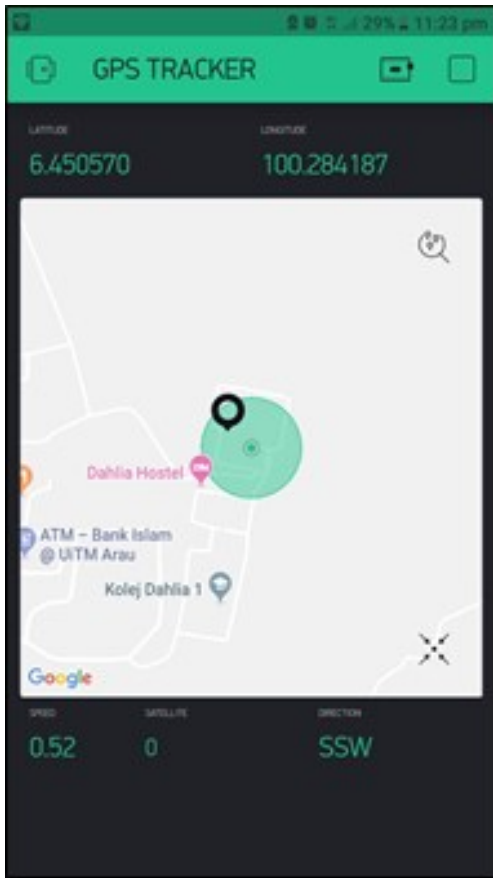

Figure 7. Data displayed in Blynk application

will be two ‘if’ statement in one loop. Firstly, for ultrasonic sensor, the distance was set to less than 50 cm and more than 0 cm then the buzzer will be triggered with frequency 10000 Hz or else buzzer will return 0 Hz. Meanwhile, the same goes to water sensor if the value read by the sensor is greater than 0 which means the sensor successfully detect the water, the buzzer will be triggered, or if there is no water, the buzzer will not be triggered.

Blynk application was used to store the longitude, latitude and display all those values. The purpose of using the GPS module was to provide a location of the visually impaired for the family. This function can be useful when the visually impaired are in harm. If the GPS is able to detect location, GPS will send the longitude, latitude, and the number of speed to the Blynk App. Figure 7 illustrates how the data was displayed in the Blynk application.

4. RESULT AND DISCUSSION

Functionality testing was carried out to determine the effectiveness of the proposed study. Ten participants took part in the functionality test, which comprises of two parts. In the functionality testing, there were two parts of the. The first part of the testing involved the detection testing with the ultrasonic sensor. The second part was the water detection

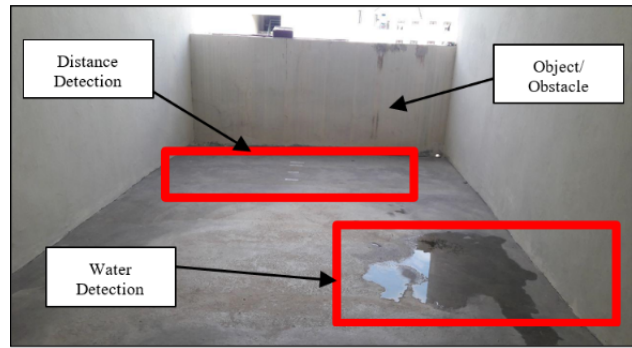

Figure 8. Illustration of the environment for the functionality test

TABLE I. Results of the obstacle testing

Distance between obstacle	Detected	Not Detected
100 cm	-	/
80 cm	-	/
60 cm	-	/
50 cm	/	-

testing with a water sensor. In these testing, both hardware were exposed to conditions and approximate readings were taken for measurement Figure 8 illustrates the path the respondents went through for functionality testing.

A. Obstacle Detection Test

The sensor was tested when participants walked with the beginning distance between object was 100 cm, 80 cm, 60 cm and lastly 50 cm.

As mentioned earlier, the sensor was set to detect the obstacles within a distance of 50 cm. As illustrated in Table I, when the participants walk from 100 cm to 60 cm, the sensor was unable to detect the object in front of them. When they reached the distance 50 cm, the sensor was able to detect an object but not particularly accurate. This was due to different ways of participants walked. In-depth, since the participants were imitated as blind people and their eyes were blindfolded, they basically did not walk in a straight direction towards the object.

By having this test, the project can have an imprecise distance value to be set in the Arduino sketches. After considering the project’s constraints with more calculation for sensor best distance to work with, it was decided for the sensor to start its reading in less than 50 cm inclusively with an obstacle in front at the sensor. Figure 9 visualizes how the respondents have been tested for distance detection.

B. Obstacle Detection Test

For the water level sensor testing, the level of water was not the issue since this project focused on to test the presence of water. The way to test this sensor was similar to the ultrasonic sensor. For this sensor, the researcher created a water puddle by pouring some water on the floor along



Figure 9. Obstacle detection test



Figure 10. Water puddle detection test

the path for participants to walk through, as illustrated in Figure 10.

The sensor was tested when participants walk on the path, and once the sensor touches the water puddle, the buzzer triggered. Right after the sensor was out of the water, the buzzer stopped beeping. Table II illustrates the conditions set up for water puddle detection testing.

Seven out ten participants managed to detect the water puddle when they walk through it. However, three of the participants was not able to detect water puddle. A few factors that lead that was, the participants did not hold and touch the proposed smart cane when they walked through the water puddle. The other factor was that the floor surface was rampant, of which the water cannot stagnate like a water puddle. This condition caused the sensor failed to detect water accurately and consistently.

TABLE II. Results of the water puddle testing

Presence of water	Yes	No
With water	/	-
Without water	-	/

5. CONCLUSION

In conclusion, this study has proposed another alternative to assist the visually impaired by integrating three different devices, which are obstacle detection, water detection and also the GPS module to monitor the visually impaired location.

In future research, we will focus on improving the prototype by adding more features such as integrating the smart cane with Internet of Things (IoT), install ultrasonic sensor in every angle so that it able to detect obstacles at low and high angle, improve buzzer sound, integrate 4G/5G module to send an information continuously to a server. This can be used to track accidents and to create an obstacles database, which can be used by visually impaired and develop a prototype that is compatible in a real-life situation where it should be more lightweight and durable. Additionally, more works related on the design of the prototype or hardware part will be conducted to ensure the usability of the proposed smart cane.

REFERENCES

- [1] R. R. Bourne, S. R. Flaxman, T. Braithwaite, M. V. Cicinelli, A. Das, J. B. Jonas, J. Keeffe, J. H. Kempen, J. Leasher, H. Limburg *et al.*, "Magnitude, temporal trends, and projections of the global prevalence of blindness and distance and near vision impairment: a systematic review and meta-analysis," *The Lancet Global Health*, vol. 5, no. 9, pp. e888–e897, 2017.
- [2] A. Riazi, F. Riazi, R. Yoosfi, and F. Bahmeei, "Outdoor difficulties experienced by a group of visually impaired iranian people," *Journal of current ophthalmology*, vol. 28, no. 2, pp. 85–90, 2016.
- [3] A. D. P. dos Santos, F. O. Medola, M. J. Cinelli, A. R. Garcia Ramirez, and F. E. Sandnes, "Are electronic white canes better than traditional canes? a comparative study with blind and blind-folded participants," *Universal Access in the Information Society*, vol. 20, no. 1, pp. 93–103, 2021.
- [4] M. M. Islam, M. S. Sadi, K. Z. Zamli, and M. M. Ahmed, "Developing walking assistants for visually impaired people: A review," *IEEE Sensors Journal*, vol. 19, no. 8, pp. 2814–2828, 2019.
- [5] W. D. Rinkel, S. van Nieuwkastele, M. C. Cabezas, J. W. van Neck, E. Birnie, and J. H. Coert, "Balance, risk of falls, risk factors and fall-related costs in individuals with diabetes," *diabetes research and clinical practice*, vol. 158, p. 107930, 2019.
- [6] V. K. Shukla and A. Verma, "Enhancing user navigation experience, object identification and surface depth detection for" low vision" with proposed electronic cane," in *2019 Advances in Science and Engineering Technology International Conferences (ASET)*. IEEE, 2019, pp. 1–5.
- [7] D. Meyer, J. Bhowmik, F. M. A. Islam, and L. Deverell, "Profiling guide dog handlers to support guide dog matching decisions," *Disability and rehabilitation*, vol. 42, no. 1, pp. 137–146, 2020.
- [8] A. Zamansky and D. van der Linden, "Activity trackers for raising guide dogs: Challenges and opportunities," *IEEE Technology and Society Magazine*, vol. 37, no. 4, pp. 62–69, 2018.
- [9] M. H. Husin and Y. K. Lim, "Inwalker: smart white cane for the

blind," *Disability and Rehabilitation: Assistive Technology*, vol. 15, no. 6, pp. 701–707, 2020.

- [10] I. Khan, S. Khusro, and I. Ullah, "Technology-assisted white cane: evaluation and future directions," *PeerJ*, vol. 6, p. e6058, 2018.
- [11] A. D. Ravi, R. K. Pandey, N. K. Ringane, and A. N. Mahajan, "Design and development of a prototype assistive mobility solution for the visually impaired," *International Research Journal of Engineering and Technology*, vol. 4, no. 6, pp. 461–467, 2017.
- [12] D. R. Patnaik Patnaikuni, "A comparative study of arduino, raspberry pi and esp8266 as iot development board." *International Journal of Advanced Research in Computer Science*, vol. 8, no. 5, 2017.

N.M.A.Nazri is a research student from the Faculty of Computer and Mathematical Sciences and is under guidance and direction from the researchers of Applied Computing and Technology Research Group.



Associate Professor Ts. Dr Shukor Sanim Mohd Fauzi is a Deputy Rector (Research and Industrial Linkage) at UiTM Perlis Branch, and also a faculty member of Faculty of Computer and Mathematical Sciences, Universiti Teknologi MARA, Perlis Branch, Malaysia. Previously, he has held Visiting Fellow position at Universitas Airlangga (2018), and Visiting Researcher position at Universitas Islam Riau (2018). He



received Diploma in Computer Science and Bachelor Science (Hons) specializing in Information Systems Engineering from the Universiti Teknologi MARA, and Master of Science (Computer Science - Real Time Software Engineering) from the Centre for Advanced Software Engineering, Universiti Teknologi Malaysia. He then obtained his PhD in Software Engineering from the University of New South Wales (UNSW), Australia and in the working group of Data61 (formerly known as Software Systems Research Group), Commonwealth Scientific and Industrial Research Organisation (CSIRO) which is based at the National ICT Research Centre Australia (NICTA), Australian Technology Park (ATP). His area of specialization includes software engineering, empirical software engineering, mining software repository, social network analysis, socio-technical congruence, computer supportive collaborative work, and software process. He has received more than 16 research grants (internal and external grants) totaling over RM1,000,000. He has published more than 100 scientific publications and has won more than 50 medals at national and international exhibition. He also is the editor for 5 books including "Software Process Improvement and Management: Approaches and Tools for Practical Development".



R.A.J.M.Gining is now serving as a lecturer at the Faculty of Computer and Mathematical Sciences, Universiti Teknologi MARA, Perlis Branch, Malaysia. He received his Diploma in Computer Science and Bachelor Science (Hons) specializing in Information Systems Engineering from the Universiti Teknologi MARA, and Master of Science in Cloud Computer from Newcastle University, United Kingdom. His research interest includes System development, IoT and machine learning. He is also a researcher of Applied Computing and Technology Research Group.



T.R Razak currently works at Universiti Teknologi MARA, Perlis Branch, Malaysia and also a faculty member of Faculty of Computer and Mathematical Sciences. He received Bachelor of Information Technology (Hons) specializing in Artificial Intelligent from the Universiti Utara Malaysia, and Master of Science (Intelligent Systems) from the Universiti Utara Malaysia. He then obtained his PhD in Computer Science from the University of Nottingham, United Kingdom and in the working group of Intelligent Modelling Analysis (IMA) and Laboratory for Uncertainty in Data and Decision Making (LUCID). He does research in Intelligence Systems, Fuzzy Logic Systems and Hierarchical Fuzzy Systems, Decision Support Systems and Interpretability. His most recent publication is "Towards a Framework for Capturing Interpretability of Hierarchical Fuzzy Systems - A Participatory Design Approach".



M. N. F. Jamaluddin received Bachelor of Computer Science (Hons) and Master of Science (Computer Science) from Universiti Teknologi MARA. After the obtainment of his master's degree, he joined Faculty of Computer and Mathematical Sciences, Universiti Teknologi MARA, Perlis Branch. He is currently served as senior lecturer and teaching programming related courses. His research interest is majorly in Machine Learning with projects related to classifications and optimizations. He is also a researcher of Applied Computing and Technology Research Group.