

Design and Implementation of Brick Making Machine Integrated with Smart IIoT Application

M. Premkumar¹, G. Naga Rama Devi² and R. Sowmya³

¹Department of Electrical and Electronics Engineering, GMR Institute of Technology, Rajam, Andhra Pradesh, India

²Department of Computer Science Engineering, CMR Institute of Technology, Hyderabad, Telangana, India

³Department of Electrical and Electronics Engineering, National Institute of Technology, Tiruchirapalli, Tamil Nadu, India

Received 7 Jul. 2019, Revised 27 Jan. 2020, Accepted 8 Apr. 2020, Published 1 May 2020

Abstract: Shelter is one of the basic needs and one of the most important challenges a man faces in his lifetime. As per the survey of PPP (Purchasing Power Parity), 21.9% of Indians are abysmal. The production of good quality, most efficient, and affordable bricks is paramount to solve housing problems in developing countries like India. This paper focuses on design, construction of an integrated machine that produces bricks for low-cost housing. With this smart and integrated machine, the production rate can be enhanced to 3600 bricks per day (8 working hours). It is an integrated machine which can produce different varieties of bricks such as clay bricks, concrete bricks, etc. Being automated through (Industrial Internet of Thing) IIoT, the speed, i.e., the production rate of bricks can be improved, which in turn improves the efficiency of the production. It produces the bricks based on the raw material fed to the machine. Assume that the raw materials provided to the machine are natural clay minerals, kaolin and shale then correspondingly produces a clay brick. This smart machine displays: i. the proportion in which the composition of raw materials is mixed, ii. The machine could be monitored via a mobile application. Also, it displays the count of bricks produced per 10 min. as well as the entire day. Thus, the machine is easily affordable for small scale enterprise (SME) with advanced features, and also the bricks produced are relatively cheap.

Keywords: Automation, Brick, IIoT, Raw material, Smart machine

1. INTRODUCTION

A brick (block) is a composite material used in construction which inbuilt consists of several other ingredients [1-2]. On a global basis, bricks are classified into four categories as represented in the flowchart (refer to Figure 1):

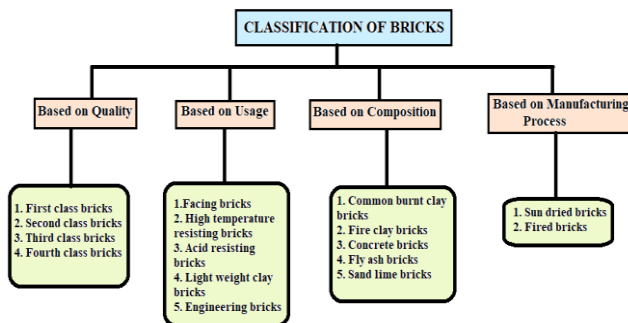

Figure 1. Classification of bricks used in the construction field

There are different automated brick making machines available in the market, but they can be accessed and afforded by only large scale industries. Concerning small scale enterprise, the available brick making machines usually focus on a single aspect such as cost, production rate, algorithm, type of brick to be manufactured, the weight of the machine, etc. If the production rate of a particular machine increase then obviously the cost, weight increases along with the complexity of the algorithm.

As mentioned in [3], the concrete block making machine can produce 300 bricks per day at a cost of sixteen thousand eight hundred rupees. It can create four blocks per one press, but it has to be operated manually. Concerning [4], a bi-directional Vibro press weighing 2,000 Kg can produce 3,000 bricks per day. It occupies an area of around 2 m² and is of the high cost. As described in [5], the multipurpose moulding machine can produce 2,215 bricks per day but has a sophisticated methodology. The average production rate of brick is around 13 seconds. Concerning reference [4], Solid/Hollow concrete block making machine can produce 1,000 bricks using a pressure vibration technique that costs high.

As in [6], the ash brick making machine is suitable for small scale industries with a production rate of 500 bricks per day with less investment. It has a simple algorithm and manually operated. In reference [7], automatic fly ash brick making machine can produce 8,000-10,000 bricks per day that have two moulds. It is an automated one that uses PLC control along with the hydraulic press. Being PLC-based, it costs higher and much suitable for large scale industries. As presented in [8], Hybrid Power Automated CSEB machine can produce 2,400 bricks per day using solar power. The system design includes PLC as a mode of control.

This paper deals with a low-cost brick machine which comprises a low-cost microcontroller, i.e., Arduino board instead of PLC's, the hydraulic system including induction motor, solenoids, compact display, and other mechanical components. The machine presented in this paper will be affordable for the SSE with the smart features. The article is organized as follows. Section 2 discusses the problem identification. Section 3 presents the design methodology of the proposed machine and explains the hardware wiring and software part of the system. Results, significant contribution, and further discussions are presented in section 4. Section 5 concludes the paper.

2. PROBLEM IDENTIFICATION

As per the literature survey, currently available brick making machines cost around 3 to 10 lakhs. The small scale industries cannot afford such available devices. As mentioned in the above introduction concrete block making machine costs less but has a very less production rate. Moreover, it has to be operated manually, and this is an additional burden to the industry. The bi-directional Vibro press is of much higher weight and occupies larger space.

Similarly, multipurpose moulding machine has less production rate with a higher production rate and runs on a

sophisticated methodology due to which identification of fault becomes difficult. The Solid/Hollow concrete block making machine uses pressure vibration technique that doesn't produce a good quality of brick. Also, the production is comparatively less concerning another similar kind of machines. The ash brick making machine is suitable for small scale industries but has less production rate. Noise is one of the problems in any sector and causes much more difficulty in the identification of faults during an emergency. Hence, there is a need to develop a machine which is cost-effective, noise-free, has ease of operation, runs on a simple algorithm, and can be easily maintained. Hence, our machine satisfies all the requirements mentioned above and would be helpful to the current era because of automation.

3. PROPOSED METHODOLOGY

Figure 2 presents the block diagram, and it gives a clear idea about the operating mechanism of the smart and integrated brick, making the machine. As we can see that whenever the source is enabled, it supplies power to the Arduino and induction motor. The Arduino gets a regulated DC supply with the help of a transformer that step-down the voltage, a rectifier that converts the supply from AC to DC and a regulator that regulates the supply to 5V required by the Arduino. Further, the Arduino supplies power to the electronic equipment such as the LCD, keypad, two-channel relay. The centrifugal pump that has been coupled to a motor creates necessary pressure to circulate the hydraulic oil between the hydraulic cylinder and the oil tank through manifold block and solenoid.

Moreover, the solenoid is controlled by a two-channel relay. On the other hand, the raw material is fed to the hopper, followed by the mould. Thus, upon compression, a brick is obtained.

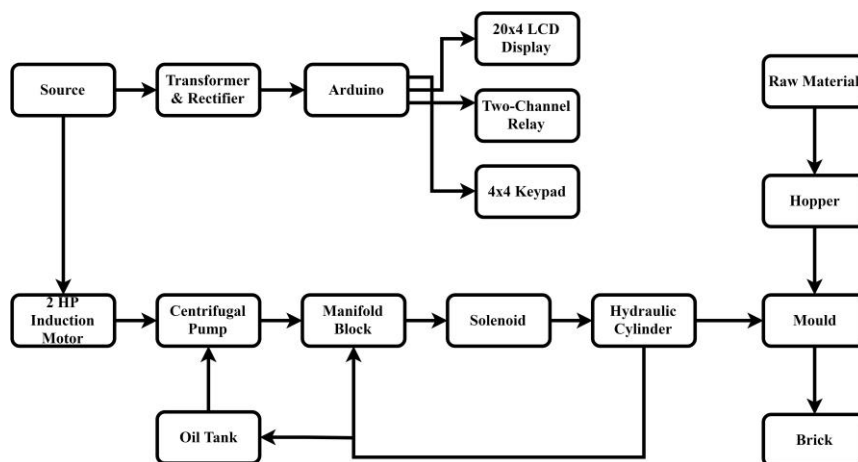

Figure 2. Block Diagram of the brick-making the machine

A. Design Considerations/Assumptions

In designing and fabricating a particular machine, there would be certain assumptions that are to be taken into account. The internal pressure or stress of the mould is evenly distributed. The type of brick, the composition of raw materials, compression pressure, weight, and standard dimensions as per the Indian standards were tabulated in Table 1 [9-11].

TABLE I. DIFFERENT TYPES OF BRICKS WITH THEIR PHYSICAL CHARACTERISTICS

Type of brick	Composition	Compression Pressure	Weight in Kg	Standard dimension in mm
Clay brick	Clay=60% Silica=30% other=10%	4-5 MPa	2.5-3	190x90x90
Concrete brick	Cement=16.66% Sand=33.33% Gravel=50%	7-8 MPa	5.2-5.8	250x210x140
Fly Ash brick	Fly Ash=60% Slaked lime=30% Gypsum=10%	10-12 MPa	2.5-2.7	230x110x70

B. Design Calculations

Hopper

The hopper, as shown in Figure 3, can hold 27 kg, i.e., it is filled with 27 kilograms for a complete cycle of operation. E.g., If it is clay brick, approximately nine bricks are made if the hopper is filled with the raw material for once.

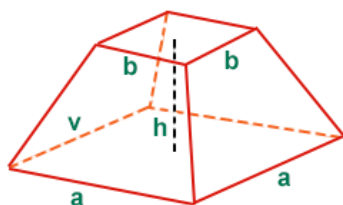

Figure 3. Inverted hopper

As per the design, the hopper is of the inverted square frustum. Say, it has the following parameters [12]. Let a be the bottom radius in m, b be the top radius in m, h be the height in m and mD be the mean density in kg/m³. Then, mass is given by Equation 1.

$$\text{Mass} = \frac{h}{3}(a^2 + b^2 + ab) * mD \tag{1}$$

For instance, the mass density of common burnt clay brick is 1900 kg/m³, a=27.5cm, b=4cm and h=50cm, and therefore, the weight that it can hold is 27.9 kg.

Motor Selection

Selection of motor was made based on the following reasons [13]:

- Power required for the hydraulic pump.
- The torque needed for the pump.
- Shaft rotational speed.
- Environmental conditions of the site of application.

Hydraulic Cylinder & Power Pump

The hydraulic cylinder and the power pump were designed after the following calculations [14]:

- Active stroke length, the speed of piston, and an internal diameter of the cylinder.
- Pump discharge, speed, power, pressure, and torque of the pump.

Mould

Depending upon the maximum stress exerted on the walls, the distribution of load intensity, cross-sectional modulus of mould walls were calculated along with the determination of factor of safety.

C. Fabrication details of the machine

The summary of the fabrication process of the machine has been presented in below Table 2.

TABLE II. FABRICATION DETAILS OF BRICK MAKING MACHINE

S. No.	Component	Description
01.	Hopper	Has a length of 770mm, the width of 480mm, the inclined height of 450mm, the perpendicular height of 400mm
02.	Mould	Inner Length of 190mm, the width of 90mm, the height of 120mm and thickness of 25mm
03.	Hydraulic cylinder	The outer diameter of 70mm, the inner diameter of 30mm and height of 350mm
04.	Movable plate	Length of 190mm, the width of 200mm and thickness of 3mm
05.	Control panel	Length of 450mm, the width of 100mm and height of 450mm
06.	Hose pipes	1m in length and diameter of 6.3mm
07.	Oil tank	Length of 460mm, the width of 300mm and height of 260mm
08.	Casing	Length of 770mm, the width of 480mm and height of 1600mm

D. Computer-Aided-Design (CAD) model

Figure 4 shows the CAD model, and it has been designed with the help of AUTOCAD 2018. It is drawn with support of the fabrication details, as stated in the above Table 2. It includes two figures out of which one is indicated with its dimensions and the other labelling its components.

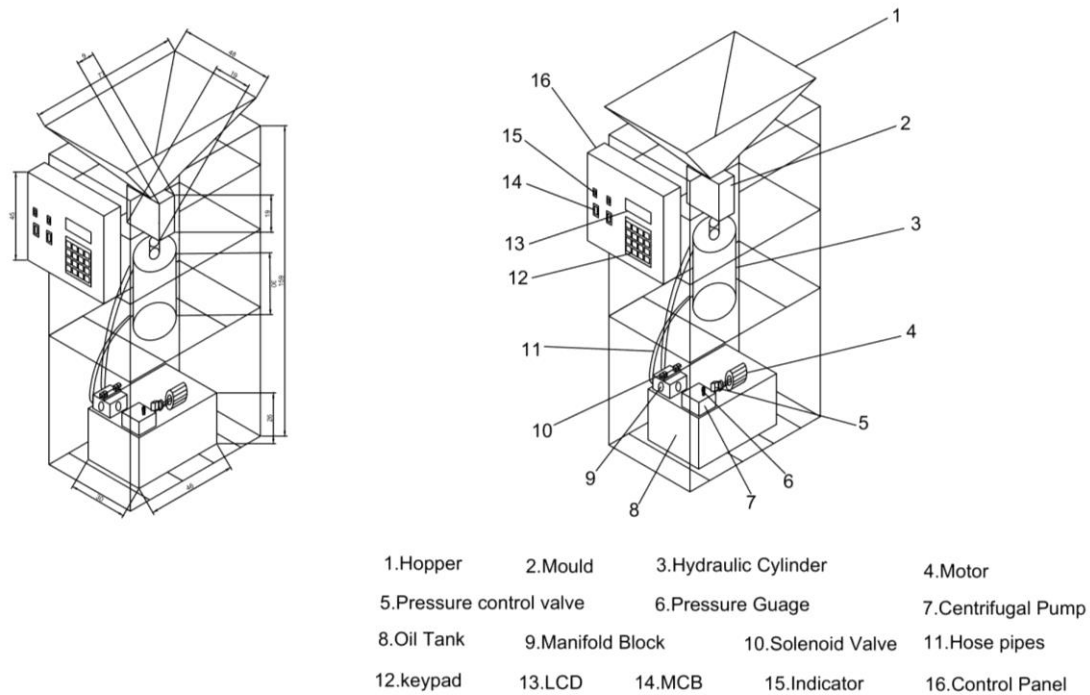

Figure 4. CAD Model of the brick making machine

E. Various Components of the System

The various components used in the brick making machine have been presented in Table 3 with its different

function. Table 3 helps the readers to understand in a better way about the components and its features.

TABLE III. VARIOUS COMPONENTS OF THE BRICK MAKING MACHINE

S.No.	Component	Description
01.	Hopper	It is a shape of inverted square frustum made of GI sheet to resist corrosion. Holds the raw material and has a control valve that opens and closes periodically.
02.	Motor	Single-phase 2HP motor with a nominal speed of 1440 rpm, rated current of 10.5 A, rated voltage of 230 V and a nominal frequency of 50 Hz.
03.	Centrifugal pump	Multistage pump that creates the pressure required for the motion of oil from the oil tank. Coupled to the motor with the help of jaw coupling.
04.	Hydraulic cylinder	Has an active stroke length of 120 mm, the maximum pressure of 16 MPa and is made of stainless steel. It is used to compress the material inside the mould.
05.	Solenoid valve	It is an electromechanical device with a power rating of 30W, rated voltage of 230 V and a current of 0.13 A. It regulates the flow of fluid between the manifold block and hydraulic cylinder [15].
06.	Hydraulic oil tank	It has a capacity of 30litres and is made of mild steel. The tank contains an oil level indicator at the bottom part of it.
07.	Hydraulic oil	Servo-68 is used as the hydraulic oil, which has a viscosity of 90 and flash point of 210 ⁰ C.
08.	Oil level indicator	It gives the measure of oil in the oil tank.
09.	Pressure control valve	It helps in regulating the pressure required for a particular brick.
10.	Pressure gauge	It measures the pressure of oil that flows in the pipe. It has a range of 0-20 MPa.
11.	Manifold block	It acts as a junction between the hydraulic tank and hydraulic cylinder. Oil circulates in the manifold block until the path is created by the solenoid valve for the flow of oil.
12.	Hosepipe	It is a flexible hollow tube designed to carry fluids.
13.	Movable plate	It closes and opens the mould at required instants. It is also used in ejecting the brick outside.

14.	Servo motor (MG995)	Two servo motors of 12kg torque and 9kg torque were employed to control the flow of raw material from hopper and motion of movable plates respectively.
15.	MCB's	Two MCB's of 25A and 10A were used to safeguard the induction motor and electronic equipment, respectively.
16.	Transformer	A step-down center-tapped transformer is used to supply the electronic equipment with 6V when the primary is excited with 230 V AC supply.
17.	Rectifier	A bridge rectifier DB107 is used to convert the AC supply to DC supply.
18.	Regulator	7805 is used to regulate the DC supply to give a constant 5V DC supply.
19.	Two-channel relay	It has two relays that control the operation of the solenoid valve electronically.
20.	Arduino (MEGA, UNO, NANO)	MEGA is used for controlling the keypad and LCD. UNO is used for controlling the relay, ultrasonic sensor. NANO is used for controlling the Wi-Fi module as well as the ultrasonic sensor.
21.	Keypad (4*4)	A keypad of 4 rows and four columns is used as an electronic input device.
22.	LCD (20*4) with I2C	LCD has four rows that accommodate 20 characters in each row. It displays the brick composition and the brick count. I2C helps in connecting the LCD with Arduino with only two cables.
23.	Ultrasonic sensor	It can sense the brick and notifies the brick count in LCD as well as in the application [16].
24.	Wi-Fi module (ESP8266)	Sends the data from the sensor to the cloud [17].

F. Overall Function of the System

The whole wiring of the machine is given in Figure 5. The structure is made as per the dimension, and it is shown in Figure 6. The machine consists of three parts, which are as follows:

Electrical & Electronic Component: It includes the control panel that consists of two indicators, one 20A MCB for controlling motor, one 10A MCB for controlling all electronic equipment like the keypad, LCD, servo, Arduino, two-channel relay, solenoid, etc.

Mechanical Part: The machine as a whole is a mechanical system which consists of a hydraulic system, skeleton, assemble of other components like mould, hopper, etc.

Software: This includes an Android App to monitor the state of the machine, and notifies the count remotely.

When the supply is switched on, the 10A MCB is made on, and it activates all the electronic equipment. Firstly, the LCD screen asks for a unique password which has been already programmed. The password is entered with the help of keyboard. If the password matches, then the display shows to enter the brick count. Thus, the number of bricks required is entered. Then it asks to select the type of brick that has to be manufactured.

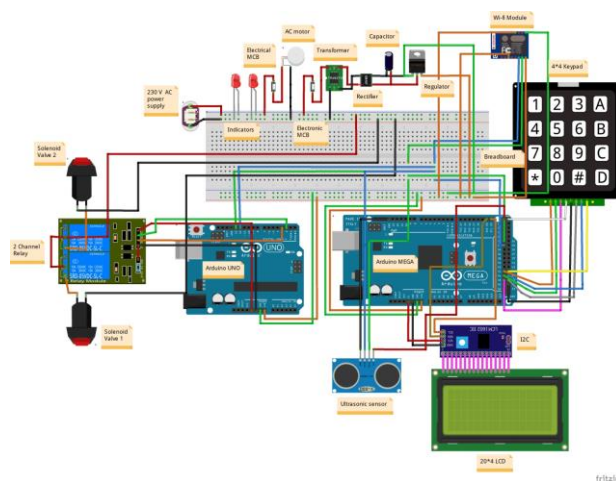

Figure 5. Connection Diagram of the brick making machine

Once it is selected, based on the given count, the composition of required brick is displayed on the LCD. From the obtained data, the raw materials are mixed in a mixer as per the proportions. (This process has to be done separately, as the machine does not include mixer). Now, the mixture of raw material is fed to the hopper. The hopper valve gets opened by a servo mechanism so that the mould gets filled with raw material. The servo is programmed in such a way that the lid gets opened and closed for some defined interval. The interval is set such that the valve remains open until the mould gets filled with raw material required for a single brick and later the valve remains closed.



Figure 6. Working prototype of smart and integrated brick making machine

When the mould is filled with raw material required for a single brick, then the movable plate that lies on the acrylic sheet closes the mould entirely from the top with the help of another servo. Now, the hydraulic system gets activated by turning on the 20A MCB. It enables the motor that starts the centrifugal pump, which is coupled to the motor. The centrifugal pump creates vacuum pressure, which is used to suck the oil from the hydraulic tank. This oil is transferred to the manifold block through hose pipes. The pressure required to compress the brick is adjusted using the pressure control valve, which can be monitored in the pressure gauge. The pressure control valve and the pressure gauge are connected in between the centrifugal pump and manifold block. The oil is circulated in the manifold block which is directed by the solenoid valve (functions with the help of two-channel relay) to the hydraulic cylinder.

The pressurized oil entering the cylinder pushes the piston upwards to compress the raw material inside the mould. After brick formation, the movable plate mentioned above moves to its initial position, i.e., it opens the mould from the top. Now the piston again moves upwards to get the brick out of the mould. Then, the movable plate pushes the brick out on to the conveyor. Once the brick is pushed on to the conveyor, the piston moves downwards with the help of pressurized oil; meanwhile, the movable plate opens the mould from the top for the formation of another brick. This process continues until the given brick count is satisfied.

G. Software Part of the System

The simplest form of using one thing to accomplish something is only by decreasing the workforce and loads of work to put on it. This has been overcome in this machine by a smart solution. The machine is being monitored and controlled with an Industrial Internet of Things (IIoT) application. Internet of Things is the

interconnection via the internet of computing devices embedded in everyday objects, enabling them to send and receive data [18-20]. In this paper, an Android application is developed, and it is running on a smartphone which monitors and controls the operation of the machine. Monitoring and controlling of Android app involves,

- To get the count of bricks made.
- To power ON and OFF the application.
- To get the alert notifications.
- Status of the machine is notified.

To get to know the count of bricks, an ultrasonic sensor is placed facing the outlet where the block comes out. The data from the ultrasonic transducer has been taken out and sent to the cloud. The data is then received by the application (App name: Smart BMM) that has been developed for the owner's purpose. In this paper, an App is designed for the owner purpose for monitoring, which is used to get the complete data regarding the machine, such as a number of bricks produced for every 10 minutes. Steps involved are,

- Extract the data from the sensor.
- Send the data from the sensor to the cloud using the ESP8266 Wi-Fi module.
- Build an Android application.
- Get the data from the cloud to an Android app.

Extract Data from the Sensor

The distance of an object can be measured using an ultrasonic sensor using sound waves. In general, the length is measured by a sound wave sent at a particular frequency and by listening to it while bounces back. The distance is obtained by calculating the elapsed time between the sound wave, and the bounced back generating wave. Thus, this gives the gap between the object and the sensor. To find the distance to the object, divide the round-trip distance in half, as shown in Equation 2.

$$\text{Distance} = \frac{\text{Speed of sound} \times \text{time taken}}{2} \quad (2)$$

The ultrasonic sensor is thus processed by using the Arduino Uno control board.

Send the Data from the Sensor to the Cloud

To code the ESP module, Arduino Nano must be used. To Program the ESP-12F, setup the connection between PC and Arduino board. Connect the Arduino board through a USB cable or USB port with the PC. Open Arduino IDE environment software and install ESP add-ons. Select the Arduino board type in Tools>Boards>Arduino Nano and Serial Port in Tools >Serial port >COM7 (example). Write the code and upload it to the board.

```

ESP8266 (Arduino IDE)
File Edit Serial Tools Help
ESP8266
#include <ESP8266WiFi.h>
#include <PubSubClient.h>

// Update these with values suitable for your network.
const char* ssid = "SmartBMM";
const char* password = "smartbmm";
const char* mqtt_server = "192.168.136.40";
int pinLed = 12;
WiFiClient espClient;
PubSubClient mqttClient(espClient);

void setup() {
  pinMode(BUILTIN_LED, OUTPUT); // Initialize the BUILTIN_LED pin as an output
  Serial.begin(115200);
  setup_wifi();
  mqttClient.setServer(mqtt_server, 1883);
  mqttClient.connect("SmartBMM");
}

void loop() {
  digitalWrite(BUILTIN_LED, !digitalWrite(BUILTIN_LED));
  delay(1000);
}
    
```

Figure 7. Arduino code for ESP8266-12F programming

There were many ways of sending data from the sensor to cloud,

- Sensor to cloud over Ethernet
- Sensor to the mobile-phone network to the cloud
- Sensor to long-range radio to the cloud
- Sensor to Wi-Fi router to the cloud
- Sensor to the Mobile phone to the cloud

In this paper, the last option of sending data from the sensor to the cloud using mobile phone application is selected for transmitting the data from the sensor to the cloud. To deal with the cloud, there should be its server, and MQTT server is used in this paper. To start with the connection to the Wi-Fi network, program the ESP-12F as once connected, ON led on the ESP module shows that the module is activated or not. Once connected, publish an announcement of brick count on the activity bar.

Build Android Application

Android application has been developed for the owner’s purpose to monitor the machine from the remote location. Android Studio is used to create an Android app. Contents of the application (Smart BMM) are as follows:

- Register and Login
- Count of Bricks

Register and Login

The initial step of the app is to register with your e-mail id. Once registration is successful, Login into the app for further usage. A database that is used for maintaining this data is “firebase.” Firebase is Google’s mobile platform that helps quickly develop high-quality apps by providing many resources like cloud storage, cloud functions, authentication, hosting, real-time database, etc. The sample screenshot the developed App is shown in Figure 8.

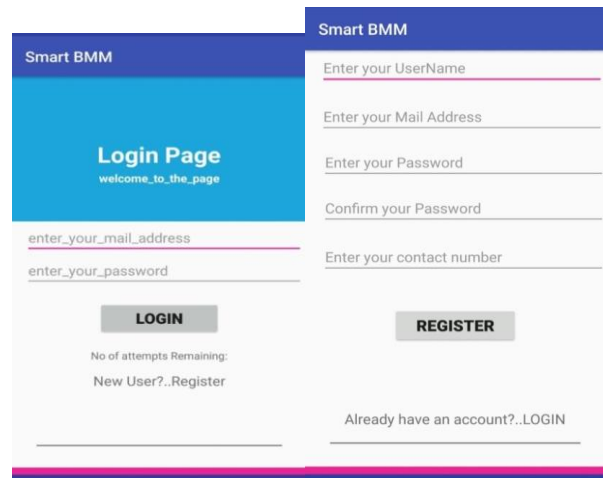

Figure 8. Screenshots of registration and login form in-app

Count of Bricks

The data, i.e., the number of bricks produced, are displayed on the activity slide. For the ease of understanding the statistics, count of bricks is represented in graphical representation, i.e. Linear Graph as shown in Figure 9.

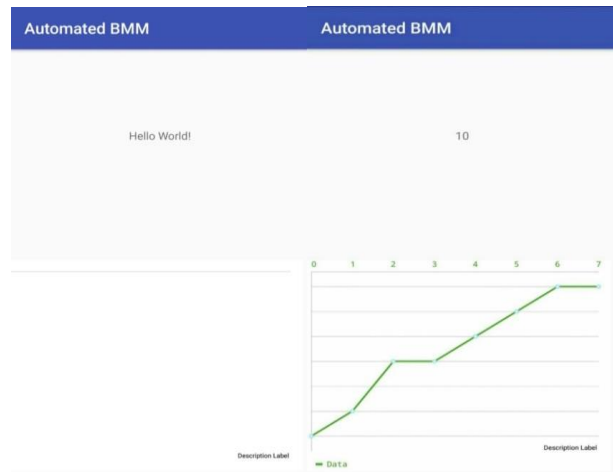

Figure 9. Screenshots of the brick count with the graphical representation in App

Get the Data from the Cloud to an Android App

The code, in such a way that android application will collect the data from the cloud. This can be done using API keys that are given by the database itself. Open the firebase account and go to firebase console. In that, create a name for the database of the application. Note the API key given in the database file, and use it in the android application for designing. Finally, an Android app is developed for monitoring and controlling the machine. The app can be used by the owner wherever he/she is. This will surely avoid the problem of maintaining the machine continuously irrespective of the times. Physical handling or



look over the machine is made accessible because of having advantages of alert notifications if necessary and for monitoring the production of bricks time to time without any flaws.

H. Various Testing of the Brick

Once after the brick is produced, it is mandatory to test it for using it in multiple applications. According to the Bureau of Indian Standards (ISS: 1077-1970), the produced bricks have to be tested in several ways, which are as follows [21-22]:

Compressive Strength of the Brick Test

The compressive strength of a brick is nothing but the ability to resist upon crushing it. In general, some 3 to 5 specimens are considered for performing this test. Firstly, one of the examples is put on the crushing machine, and pressure is applied until it breaks. The maximum value of pressure at which it breaks is nothing but the compressive strength of the brick.

Water Absorption Test

Initially, the bricks are weighed in dry condition and then immersed in water for a whole day. After 24 hours, the blocks are taken out and again weighed. The difference in weights gives the water absorbed by the bricks. Thus, the percentage of water consumed is calculated. The block that absorbs less water is of better quality.

Efflorescence Test

It helps in finding out the presence of alkalis in bricks, which is harmful and forms a white layer on its surface by absorbing moisture. For this, the blocks are immersed in fresh water for 24 hours and then dried. After drying, they are examined for the formation of white layer indicating the presence of alkalis.

Hardness Test

A scratch is made on the brick surface with a hard thing. If it doesn't leave any mark, then it is of good quality.

Size, Shape and Color Test

A group of bricks is stacked together along the length width and height to verify the size and shape. If all the bricks appear the same in shape and size, then they can be used for construction. Also, if they possess a bright & uniform color, they are of good quality.

Soundness Test

A good quality brick gives a clear metallic ringing sound when it is struck with other brick of the same kind.

Structure Test

If a broken brick has any flaws, cracks, or holes on the broken face, then the brick is not of good quality.

I. Determination of the Mechanical and Physical Properties of the Bricks

The mechanical properties such as the compressive strength, bulk density, moisture content, etc. are examined as per the ISS: 1077-1970 [21]. The physical properties such as the shape, size, color, soundness, structure, etc. were investigated. For the bulk density determination, five bricks were used, while for the compressive strength, three sets of five bricks were used in both wet and dry conditions.

4. RESULTS AND DISCUSSION

The results of bulk density and the physical characteristics have been presented in Table 4 for further discussion. The resultant brick fabricated using the machine is shown in Figure 10.

TABLE IV. BULK DENSITY AND PHYSICAL CHARACTERISTICS

Sample	Production Period in seconds	Brick Height in M	Weight in Kg	Volume in m ³	Bulk Density in Kg/m ³
1	9	0.090	2.912	0.00153	1903
2	8.5	0.099	3.051	0.00169	1805
3	8	0.096	3.023	0.00164	1843
4	8.5	0.089	2.952	0.00152	1942
5	8	0.088	2.861	0.00150	1907
Average	8.4	0.092	2.95	0.00157	1880

Where the production period indicates the time taken for manufacturing one brick, the volume of the brick is presented in Equation 3. Length=0.19m, Breadth=0.09m, Height varies accordingly (during compression).

$$\text{Volume} = \text{Length} \times \text{Breadth} \times \text{Height} \quad (3)$$

The bulk density is presented in Equation 4.

$$\text{Bulk density} = \frac{\text{Weight}}{\text{Volume}} \text{ Kg/m}^3 \quad (4)$$

The results of the compressive strength of the brick under wet and dry conditions have been presented in Table 5.

TABLE V. COMPRESSIVE STRENGTH OF BRICK UNDER WET AND DRY CONDITIONS

Sample	Wet		Dry	
	Max. load in (KN)	Compressive strength in N/mm ²	Max. load in (KN)	Compressive strength in N/mm ²
1	58.56	3.44	140.01	8.23
2	57.98	3.41	141.92	8.34
3	57.19	3.36	140.87	8.28

4	58.24	3.42	139.69	8.21
5	58.39	3.43	141.25	8.30
Average	58.01	3.41	140.74	8.27

From Table 5, Maximum load is the load until which the brick sustains without breaking. The compressive strength of the brick is presented in Equation 5.

$$\text{Compressive strength} = \frac{\text{Max load}}{\text{Area of compression}} \text{ N/mm}^2 \quad (5)$$

Where the area of compression is given as 0.017m².



Figure 10. The resultant output of the brick making machine

A. Cost Implication (Cost Analysis)

The cost of the machine includes the cost of equipment used for manufacturing the machine along with the transportation which is presented in Table 6.

TABLE VI. BILL OF MATERIALS

S. No.	Name of the equipment	Quantity	Cost in Rs. (\$)
01.	Single phase 2HP motor	01	8600 (122)
02.	16MPa hydraulic cylinder	01	8000 (113)
03.	230V Two-way solenoid valve	01	4000 (57)
04.	Hydraulic oil tank	01	1000 (14)
05.	Oil level indicator	01	250 (4)
06.	Centrifugal pump	01	1000 (14)
07.	Pressure control valve	01	800 (11)
08.	Pressure gauge	01	150 (2)
09.	Manifold block	01	300 (4)
10.	Hose pipes (1m each)	02	1000 (14)
11.	Plates	03	700 (10)
12.	30 mm Socket	01	200 (3)
13.	Mould	03	300 (4)
14.	Servo motors (9 Kg & 12 Kg torque)	02	1600 (23)
15.	Hopper valve	01	500 (7)
16.	Hopper	01	500 (7)
17.	4mm Screws and Nuts	Few	500 (7)
18.	MCB's (20A, 10A)	02	100 (1)
19.	Transformer	01	500 (7)
20.	Two-channel relay	01	150 (2)
21.	Arduino (Mega, Uno, Nano)	02	1650 (23)
22.	20x4 LCD with i2c	01	800 (11)

23.	4x4 Keypad	01	150 (2)
24.	Ultrasonic sensor	01	200 (3)
25.	Jumper cables	Few	250 (4)
26.	Connecting wires	Few	250 (4)
27.	Hydraulic oil(servo 68)	As per requirement	2500 (40)
28.	ESP8266 12F Module	01	200 (3)
29.	Transportation	-	10000 (141)
GRAND TOTAL			44650 (633)

B. Innovations/Major Contributions

- It produces a variety of bricks based on the raw material fed to the machine. It means that, say, if it is a fly-ash brick, requires the composition of raw materials to be: Fly Ash=50%, Sand=36%, Cement=8%, Water=6%. Similarly, for other brick say, concrete brick the composition of raw material may vary but it the same machine is employed to produce the fly ash brick as well as the concrete brick.
- It displays the proportion of materials needed to be mixed, indicates the shortage of any material of the composition, the moisture content present in the raw material, etc.
- As and when specifying the type of brick and a particular count of bricks, the machine automatically calculates the proportion of the raw materials to be mixed and displays them on a monitor, based on the type of brick (clay or fly ash or concrete) chosen. It also indicates the shortage of specific material in the composition (whether it is sand or fly ash, etc. in a fly ash brick) and finally checks for the moisture content.
- The Smart & Integrated brick making machine could be monitored with the help of a simple mobile app that displays the count of bricks produced per hour as well as the whole day. It stores the data in a cloud that can be retrieved whenever required. Not only that, it provides alerts to the owner through which machine state can be known, i.e., whether it is in on or off state. Along with the above mentioned, as a safety measure, it also can alert the owner in case of any fire accidents.
- The brick count is displayed on the LCD.
- It has a replaceable mould for producing different varieties of bricks based on their dimensions.
- Bricks could also be made from granite dust, i.e., useful thing (brick) could be made from the by-product of other.
- Economically feasible and even remote rural areas can also afford so that it benefits society.
- Ease of operation and eco-friendly.

C. Further Discussions

Compressive pressure

The compression pressure for a clay brick is maintained at 5MPa, for a concrete brick it is kept at



8MPa, and for a fly ash brick, it is maintained at 12MPa. This variation of pressure can be adjusted by a pressure relief valve within the machine. The machine has maximum pressure adjustability up to 20MPa. The change of pressure would be indicated in pressure gauge.

Production rate

The production rate is the measure of output of any machine. The average production period of a brick is around 8 seconds as obtained from Table 4.

$$\text{Production rate} = \frac{60 \times 60 \times 8}{8} = 3,600 \text{ bricks per day.}$$

Bulk density

The bricks having higher bulk density have higher strength. From Table 4, the average mass density is found to be 1880 Kg/m³. The bulk density could be improved by varying the proportion of the raw materials.

5. CONCLUSION

The smart and integrated brick making machine was designed to give a reasonable production rate with an affordable investment. It is an automated model with a simple algorithm. It is a multipurpose machine that can produce different types of bricks with good quality by merely replacing the mould. The cost of production of the machine is around forty-four thousand six hundred fifty only. The machine has been designed to perform the task within a short period. It can achieve mass production, which increases the efficiency of the plant that reduces the workload and also reduces the production cost.

Brick is an essential requirement for construction and is a basic income for many people in India. Child labour is one of the significant issues and surprisingly, who are mostly involved in brick manufacturing industries. It can reduce child labour by using automatic brick making the machine. By adopting these machines, the production rate of an enterprise will be increased. In the future, there will be a lot of demand for the different type of bricks that can be reached by automated brick making machines. The following are the recommendations.

- A temperature sensor can be placed nearby motor which can sense the higher range of temperature and gives an alert as an alarm.
- The machine can be made as a movable one.
- The conveyor belt can be attached at the output side for collecting the ejected bricks.

ACKNOWLEDGMENT

We extend our thankfulness to GMR Institute of Technology, Rajam, Andhra Pradesh, India, for providing facility and allowing us to validate the performance of the system at the laboratory.

REFERENCES

- [1] D. Sadek, and R. Hashim, "A review on bricks and stabilized compressed earth blocks," *Scientific Research and Essays*, vol. 6, no. 3, pp. 499-506, 2011.
- [2] NPCS Board of Consultants & Engineers, "The Complete Technology Book on Bricks, Cement and Asbestos", NIIR Project Consultancy Services, pp.8-71, 2007.
- [3] D.S. Madara, S.S. Namango and D. Arusei, "Innovative conceptual design of manual-concrete-block-making-machine", *Innovative Systems Design and Engineering*, vol. 7, no. 7, pp.41-52, July 2016.
- [4] Catalogue for Machines developed and promoted for production of cost-effective building components, Building material, and technology promotion council, pp. 2-33, April 2017.
- [5] S.O. Yakubu, and M.B. Umar, "Design, Construction and Testing of a Multipurpose Brick/Block Moulding Machine", *American Journal of Engineering Research*, vol. 4, no. 2, pp. 33-43, June 2015.
- [6] S. Kaushik, and A. Guptha, "Design and fabrication of ash brick machine", *International Journal of Scientific and Engineering Research*, vol. 7, no. 3, pp. 604-609, March 2016.
- [7] S. Mehtha, and H. Prajapati, "Design of automatic fly ash brick manufacturing machine components", *ELK Asia Pacific journals*, pp. 3-9, 2017.
- [8] A. Ayyapan. and S. Milan, "Design of hybrid powered automated compressed stabilized earth block (CSEB) machine", *International Conference for Convergence in Technology, India*, pp. 1-6, April 2018.
- [9] P.B. Lourenco, and F.M. Fernandes, "Handmade clay bricks: chemical, physical, mechanical properties, *International Journal of Architectural Heritage*, vol. 4, no. 1, pp. 2-35, January 2010.
- [10] F. Alwani W. Chick, B. Hisham, and A. Bakar, "Properties of concrete block containing rice husk ash subjected to Girha", *International Journal of Research and Reviews in Applied Sciences*, vol.8, no. 1, pp. 57-64, July 2011.
- [11] S.K. Verma, D.K. Ashish, and J. Singh, "Performance of bricks and brick masonry prism made using coal fly ash and coal bottom ash", *Advances in Concrete Construction*, vol.4, no. 4, pp. 231-240, December 2016.
- [12] S.O. Butuner, "Using history of mathematics to teach volume formula of a frustum pyramids: dissection method", *Universal Journal of Educational Research*, vol. 3, no. 12, pp. 1034-1048, July 2015.
- [13] "Motor Efficiency, Selection, and Management", *A Guidebook for Industrial Efficiency Programs*, Publication of Consortium for Energy Efficiency, pp. 13-25, September 2013.
- [14] K. Yang, S. Guan, and C. Wang, "The design and calculation for a hydraulic cylinder of work piece hydraulic clamping system of a special CNC machine for guide disk", *Procedia Engineering*, vol.16, pp.418-422, May 2011.
- [15] W. Shifeng, W. Zhou, J. Ke, and H. Yan, "Design and application of hydraulic pressure system for new fly ash brick," in *Proc. IEEE International Conference on Aircraft Utility Systems*, pp. 895-899, 2016.
- [16] A.C.M. Parves, "An ultrasonic sensor for distance measurement in automotive applications", *IEEE Sensors Journal*, vol. 01, no. 2, pp. 143-154, August 2011.
- [17] M. Malathi, A. Gowsalya, "Home automation on ESP8266", *SSRG International Journal of Computer Science and Engineering*, Special issue, pp. 1-4, April 2017.
- [18] H. Boyes, B. Hallaq, J. Cunningham, and T. Watson, "The industrial internet of things (IIoT): An analysis framework," *Computers in Industry*, vol. 101, pp. 1-12, 2018.
- [19] E. Sisinni, A. Saifullah, S. Han, U. Jennehag and M. Gidlund, "Industrial Internet of Things: Challenges, Opportunities, and Directions," *IEEE Transactions on Industrial Informatics*, vol. 14, no. 11, pp. 4724-4734, 2018.

- [20] Ding Zhang, Ching Chuen Chan, George You Zhou, Enabling Industrial Internet of Things (IIoT) towards an emerging smart energy system, *Global Energy Interconnection*, vol. 1, no. 1, pp. 39-47, 2018.
- [21] "Common burnt clay building Bricks-Specification", Bureau of Indian Standards, 2005.
- [22] M. Bošnjak-Klečina, S. Lozančić, "Testing of physical and mechanical properties of bricks and mortar in historic structures," *Technical Gazette*, vol. 17, no. 2, pp. 209-215, 2010.



M. Premkumar received his B.E. degree in Electrical and Electronics Engineering from Sri Ramakrishna Institute of Technology, Coimbatore, India, in 2004; and his M.E. degree in Applied Electronics from Anna University of Technology, Coimbatore, India, in 2010. He received his Ph.D. degree from Anna University, Chennai, India under

ICE department in 2019. He is presently working as an Assistant Professor at GMR Institute of Technology, Rajam, India. He has more than 11 years of experience in teaching and he has published more than 40 papers in various peer-reviewed indexed journals. His current research interests include microinverters, non-isolated and isolated dc-dc converters, and solar PV MPPT techniques.



G. Naga Rama Devi received her MCA degree from in SV University, Tirupati, India, in 2000; and her M.Tech. degree in Computer Science from ANU, Guntur, India, in 2010. She received her Ph.D. degree from Sri Padmavathi Mahila University, Tirupati, India, in 2016. She is presently working as Professor at CMR Institute of Technology,

Hyderabad, India. She has more than 16 years of experience in teaching and she has published more than 20 papers in various peer-reviewed indexed journals. Her current research interests include machine learning, IoT, image processing and pattern recognition.



R. Sowmya received her B.E. degree in Electrical and Electronics Engineering from Saranathan College of Engineering, Tiruchirappalli, India in 2013 and M.Tech. Degree in Energy Engineering from National Institute of Technology, Tiruchirappalli, India, in 2015. Currently, she is pursuing Ph.D. in National Institute of Technology,

Tiruchirappalli, India. She has published more than 20 papers in various peer-reviewed indexed journals. Her research interest includes control systems, Electric vehicle and Renewable Energy.